



2026:DHC:2598



* **IN THE HIGH COURT OF DELHI AT NEW DELHI**

% *Judgment delivered on: 28.03.2026*

+ **C.A.(COMM.IPD-PAT) 486/2022**

NEC CORPORATION

.....Appellant

versus

**ASSISTANT CONTROLLER OF PATENTS AND
DESIGNS**

....Respondent

Advocates who appeared in this case

For the Appellant : Mr. Vineet Rohilla, Mr. Rohit Rangi, Ms. Vaishali Joshi and Ms. Gurneer Chawla, Advocates.

For the Respondent : Mr. Rohan Jaitley, CGSC with Mr. Varun Pratap Singh, Mr. Dev Pratap and Mr. Yogya Bhatia, Advocates.

**CORAM:
HON'BLE MR. JUSTICE TEJAS KARIA**

JUDGMENT

TEJAS KARIA, J

INTRODUCTION

1. This is an Appeal filed under Section 117A(2) of the Patents Act, 1970 (“**Act**”) seeking quashing and setting aside of order dated 21.06.2022 (“**Impugned Order**”) passed by the Assistant Controller of Patents and Designs (“**Respondent / Controller**”) under Section 15 of the Act refusing the Patent Application No. 201717010986 filed on 28.03.2017 titled as “*VIDEO CODING DEVICE, VIDEO DECODING DEVICE, VIDEO*”



2026:DHC:2598



CODING METHOD, VIDEO DECODING METHOD AND PROGRAM (“**Subject Application**”).

FACTUAL MATRIX

2. On 15.10.2014, the Appellant filed the Japan Patent Application No. 2014-204392 (“**JP Application**”). On 12.08.2015, the Appellant filed the Paris Cooperation Treaty Patent Application No. PCT/JP2015/004037 (“**PCT Application**”), which claimed priority from the JP Application.

3. On 28.03.2017, the Appellant filed the Subject Application before Patent Office, New Delhi as a National Phase Application of the PCT Application. The Appellant filed a request for the examination of the Subject Application on 28.03.2017. A formal request upon filing of Form-13 for making amendments to the claims of the Subject Application along with amended claim nos. 1 to 10 was filed by the Appellant on 03.05.2017.

4. The Respondent issued a First Examination Report dated 29.01.2020 (“**FER**”). Response to the FER was filed by the Appellant on 15.04.2020 (“**Reply**”). The Respondent issued a hearing notice dated 22.03.2021 (“**Hearing Notice**”) scheduling the hearing for 16.04.2021 (“**Hearing**”). The Hearing was held and the Appellant filed the post-hearing written submissions along with claim nos. 1 to 8 on 30.04.2021 (“**Written Submissions**”).

5. *Vide* the Impugned Order, the Respondent has refused the Subject Application on the ground that the invention claimed in the Subject Application lacks inventive step under Section 2(1)(ja) of the Act, in view of the disclosure of the cited prior arts: (i) JOSID R ET AL, “HEVC Screen Content Coding Draft Text 1”, 18. JCT-VC MEETING; 30/06/2014-09/07/2014; SAPPORO; (JOINT COLLABORATIVE TEAM ON VIDEO



2026:DHC:2598



CODING OF ISO/IEC JTC1/SC29/WG 11 AND ITUT SG.16); no. JCTVCR1005-v2 (“**D1**”); (ii) LI ZHANG et al., “SCCE5 Test 3.2.1: In-loop color-space transform”, Joint Collaborative Team on Video Coding (JCTVC) of ITU-T SG 16 WP 3 and ISO/IEC JTC 1/SC 29/WG 11 18th Meeting, Sapporo, JP, JCTVCR0147 (“**D2**”); and (iii) W02015143671 (“**D3**”).

SUBMISSIONS ON BEHALF OF THE APPELLANT

6. The learned Counsel for the Appellant made the following submissions:

- 6.1. The invention claimed in the Subject Application relates to a video coding device / method and a video decoding device / method. A digital colour image is composed of Red, Green, and Blue (“**RGB**”) digital images having the said three colour components. To increase the compression efficiency when the colour image is transmitted through a transmission line (i.e., to decrease the data amount), RGB digital image is generally transformed to signals in a different colour space. For example, the image signal is transformed to a signal in a colour (“**YCoCr**”) space where a combination of a luma signal (“**Y**”) and chroma signals (“**Co, Cr**”) are composed.
- 6.2. A technique of ‘adaptive colour transform in residual domain’ is used for further increasing compression efficiency. It is a technique wherein it is possible to select, in block units (per block), whether to compress the prediction error signal of the RGB space directly or to transform the prediction error signal first to a signal of the YCoCr space.



2026:DHC:2598



- 6.3. A chroma quantization offset technique is used to increase the subjective image quality by adjusting the quantization strength for each colour component of a colour space. A quantization parameter (“QP”) for the chroma signal is generated by transforming the QP for the Y by using an offset value. In High Efficiency Video Coding (“HEVC”) standard, a first chroma quantization offset is applied to Co, and a second chroma quantization offset is applied to Cr. Therefore, if the adaptive colour transform in residual domain is combined with the chroma quantization offset, the block compressed in the RGB space and the block compressed in the YCoCr space share the quantization strength.
- 6.4. The object of the present invention is to provide a video coding device, a video decoding device, a video coding method, a video decoding method, and a program capable of preventing a deterioration in the subjective image quality improvement effect in the case where the adaptive colour transform in residual domain and the chroma quantization offset are used in combination. In a video coding device illustrated in Figure No. 18 of the Complete Specification of the Subject Application.
- 6.5. Figure No. 1 of the Complete Specification of the Subject Application, reproduced hereunder, illustrates an embodiment of a video coding device according to present invention.



FIG. 1

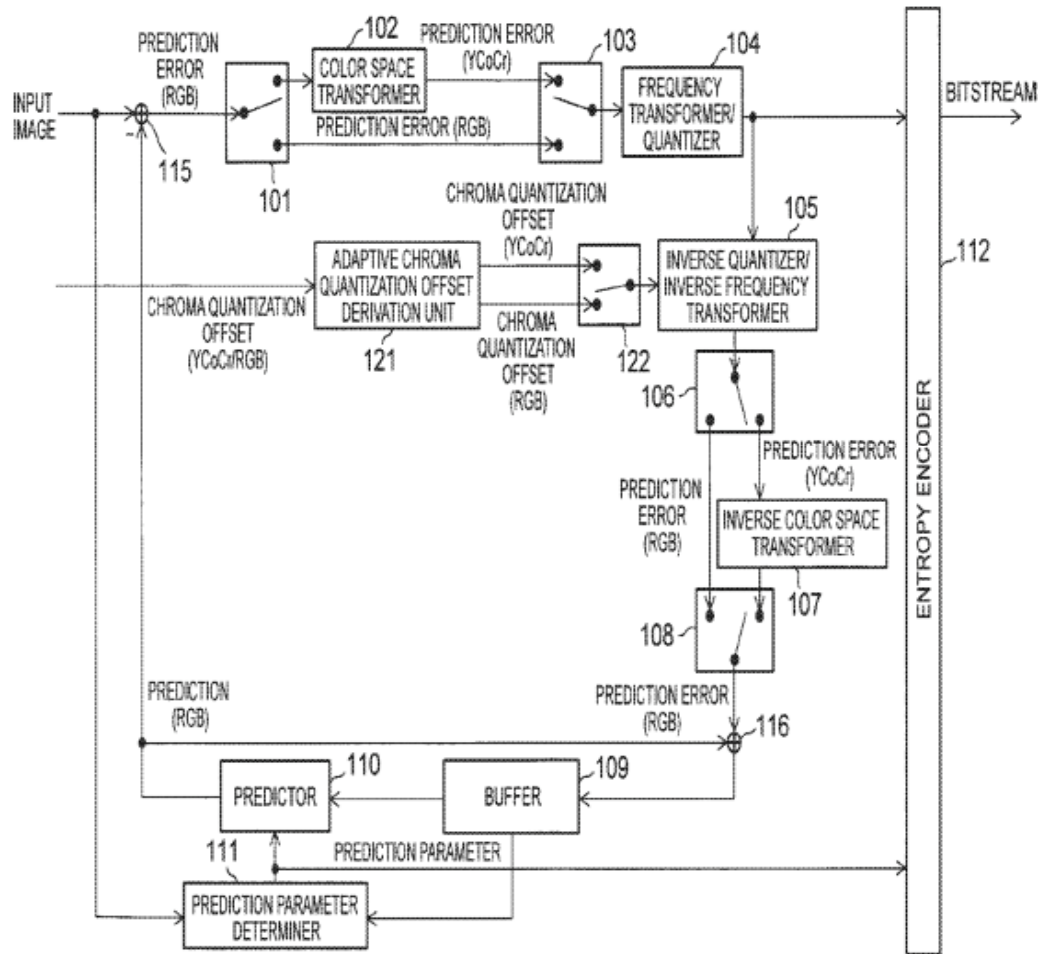

6.6. The switch 101, the colour space transformer 102, the switch 103, the frequency transformer / quantizer 104, the inverse quantizer/inverse frequency transformer 105, the switch 106, the inverse colour space transformer 107, the switch 108, the buffer 109, the predictor 110, the subtractor 115, and the adder 116 operate in the same manner as those illustrated in Figure No. 18 of the Complete Specification of the Subject Application. The video coding device as illustrated in above Figure No. 1 of the Complete Specification of the Subject



Application further includes an adaptive chroma quantization offset derivation unit 121 and a switch 122.

- 6.7. In the case where the adaptive colour transform in residual domain is performed, the adaptive chroma quantization offset derivation unit 121 outputs the derived chroma quantization offsets for the YCoCr space to the switch 122. When the compression is performed in the RGB space, the adaptive chroma quantization offset derivation unit 121 outputs the derived chroma quantization offsets for the RGB space to the switch 122. The adaptive chroma quantization offset derivation unit 121 recognizes whether the compression is performed in the RGB space or in the YCoCr space.
- 6.8. The frequency transformer / quantizer 104 adjusts the QP by using the chroma quantization offset decided by the prediction parameter determiner 111. The operations of the video coding device other than the above operations are the same as the operations of the video coding device illustrated in Figure No. 18 of the Complete Specification of the Subject Application. Reliance was placed upon Paragraph No. [0075] of the Complete Specification of the Subject Application which is reproduced hereunder:

“[0075] The prediction parameter determiner 111 stores the values of the chroma quantization offsets for the RGB space and the values of the chroma quantization offsets for the YCoCr space in advance and appropriately supplies the values of the chroma quantization offsets for the RGB space or the values of the chroma quantization offsets for the YCoCr space to the frequency transformer / quantizer 104. In such case,



the values of the chroma quantization offsets for the RGB space and the values of the chroma quantization offsets for the YCoCr space are included in the prediction parameters supplied to the entropy encoder 112. The entropy encoder 112 signals the values of the chroma quantization offsets for the RGB space and the values of the chroma quantization offsets for the YCoCr space.”

6.9. The Respondent has asserted that the claims of the Subject Application were anticipated by ‘prior claiming’ in view of the PCT Application of D3. However, D3 fails to disclose the following features claimed in the Subject Application:

- a. D3 is silent about the plurality of colour spaces and D3 is not significant to adjust QP values in both colour spaces (e.g., YCoCg) in order to compensate for amplification of energy of quantization error in inverse colour space conversion operations. Claim no. 1 of D3 claims only the per component colour space adjustment factor for the colour components of second colour space; and
- b. the values of the adjustment factor are pre-set and cannot be said to be dynamic or adaptive as claimed in the Subject Application.

The claims of the present invention are not anticipated by ‘prior claiming’ in view of D3. Moreover, the claimed technical features of the present invention are not disclosed in D3.

6.10. The obviousness is a question of law based on facts and the burden to prove is on the party which alleges however, after the party which alleges makes out a *prima facie* case of invalidity



2026:DHC:2598



on the ground of obviousness, the burden shifts on the inventor to disapprove obviousness. The prior publication should contain a clear description and provide clear instructions / enablement to do or carry out the same. However, the respondent has failed to construe the claims and has failed to map each of the feature of independent claims. The present invention is clearly distinguishable from D1 and D2 and is not obvious in view of D1 or D2 or the combination of D1 and D2. Reliance was placed upon the decision in ***F. Hoffman-La Roche Ltd. & Anr. v. Cipla Ltd.***, 2015 SCC OnLine Del 13619 while making the above submission.

- 6.11. In D1, there is no concept of determination / identification of the colour space for computation of the QP. The equations in Section 8.6.2 of D1 does not indicate computation of the QP for plurality of colour spaces (RGB or YCoCr or any other) as being utilized.
- 6.12. Hence, unlike the present invention, D1 has no concept of *“deriving an adaptive chroma quantization offset for each of the plurality of color components. In Section 8.6.2, there is no description regarding a plurality of color spaces”*. In fact, the concept of plurality of colour spaces is altogether missing from D1. At most, the equation (8-261) in Section 8.6.2 of D1 implies that the value for the luma component is -5, which is an ‘adjusting factor’ in the sense of D3. That is, the values in the equations (8-261) to (8-263) in Section 8.6.2 of D1 compensate for the differences among the energies (i.e., sum of the squares



- of the components in the respective columns of the matrix). In D1, since matrices for conversion between the two-colour spaces are preset, and consequently the values (-5, -5, -3) in Section 8.6.2 of D1 are preset. Therefore, D1 cannot suggest deriving a chroma quantization for the selected colour space.
- 6.13. In the Impugned Order, the Respondent has considered the values (-5, -3, -5) in Section 2 of D2 as the claimed offsets. However, the values are identical to those disclosed in D3, the matrices of Section 2 of D2 are identical to those disclosed in D3. D2 discloses the same technique as that of D3. Thus, as with D3, it is not accessory to adjust QP values in the second colour space (e.g., RGB) while QP values in the first colour space (e.g., YCoCg) is adjusted in the invention of D2.
- 6.14. D1 and D2 cannot teach or suggest at least the feature “*deriving a chroma quantization offset, which is a parameter for adjusting a quantization parameter of each chroma component, for each of the plurality of color spaces*”. Additionally, the present invention selects a colour space in coded black units, however, D1 and D2 fail to teach that.
- 6.15. The Respondent has failed to apply any test for the assessment or novelty and inventive step of the present invention. The novelty and inventive step are further substantiated by grant of patents and various countries including the US, Australia, Japan among several countries.
- 6.16. Accordingly, the Impugned Order is liable to be set aside, and the present Appeal may be allowed.



SUBMISSIONS ON BEHALF OF THE RESPONDENT

7. The learned CGSC for the Respondent made the following submissions:

- 7.1. The Respondent in the Impugned Order has mentioned that the Subject Application lacks inventive step.
- 7.2. Similarly, looking independently at D2, the present invention lacks an inventive step. Besides, D3 was cited in the Hearing Notice *vis-à-vis* the present invention. The Appellant did not provide any argument during the Hearing or in the post-hearing Written Submissions regarding priority claiming. However, from the publication, it was clear that it is related to prior claiming subject matter. In the Impugned Order, D3 is considered with respect to the post-hearing Written Submissions of the Appellant. However, it does not affect the merit of the Subject Application as the Subject Application does not have an inventive step considering D1 and D2 independently.
- 7.3. D1 derived the chroma QP for the Cb and Cr components, Qp'_{Cb} and Qp'_{Cr} , are derived as mentioned in D1 is hereunder:

$$Qp'_{Cb} = qP_{Cb} + QpBdOffset_C \quad (8-259)$$

$$Qp'_{Cr} = qP_{Cr} + QpBdOffset_C \quad (8-260)$$

The quantization parameter qP is derived as follows:

– If $cIdx$ is equal to 0,

$$qP = Qp'_{Y} + (cu_residual_act_flag[xTbY][yTbY] - 5 : 0) \quad (8-261)$$

– Otherwise, if $cIdx$ is equal to 1,

$$qP = Qp'_{Cb} + (cu_residual_act_flag[xTbY][yTbY] - 5 : 0) \quad (8-262)$$

– Otherwise ($cIdx$ is equal to 2),



$$qP=Qp'_{cr}+(cu_residual_act_flag[xTbY][yTbY]?-3:0) \quad (8-263)''$$

a variable cIdx specifying the colour component of the current block. The abovementioned equations (8-262) and (8-263) are adjusting QP of chroma components (Qp'_{cb} and Qp'_{cr}). The cu_residual_act_flag equal to 1 specifies that adaptive colour transform is applied to the residual samples of the current coding unit. The cu_residual_act_flag equal to 0 specifies that adaptive colour transform is not applied to the residual samples of the current coding unit.

- 7.4. The main differentiating feature of the present invention *vis-à-vis* D1 is “*deriving a chroma quantization offset, which is a parameter for adjusting a quantization parameter of each chroma component, for each of the plurality of color spaces*”. Since each of the plurality of colour spaces means each colour space that is having colour components. The chroma quantization offset for each of the plurality of colour spaces is related to colour components of colour space. Thus, adjusting a QP of each chroma component has been disclosed in the equations (8-262) and (8-263) of D1.
- 7.5. The Appellant has taken the contradictory stands in the Appeal. The Appellant accepted in Paragraph No. 2 in post-hearing Written Submissions that “*Section 8.6.2 of D1 teaches no more than deriving an adaptive chroma quantization offset for each of the plurality of color components. In Section 8.6.2, there is no description regarding a plurality of color spaces*”. It is accepted that D1 teaches deriving an adaptive chroma



quantization offset for each of the plurality of colour components. Here colour component represents the component of colour space. Further, equations (8-261) to (8-263) show the adjusting a QP for each chroma component of colour space. Whereas, in the Appeal, the Appellant has argued that Section 8.6.2 of D1 does not describe the concept of ‘chroma quantization offset’. Further, the Appellant has argued that Section 8.6.2 only describes the adjustment of the luma component, but such an argument was not provided in the post-hearing Written Submissions.

7.6. D2 discloses, different QP (QP-5, QP-3, QP-5) are used for Y, Co, and Cg component, respectively. It is used in YCoCg space using the delta QPs by (-5, -3, -5) for adjusting the ‘normal’ QP when the colour space transform is applied. A person skilled in the art (“**PSITA**”) understands from this disclosure clearly and unambiguously that if the colour space transform is not applied, the ‘normal’ QP should not be modified; thus, the delta QP, or the QP offset should be 0. For original colour spaces, the delta QP, or the QP offset should be 0. From D2, it is clear that the delta QP, or the QP offset is different for different colour components for different colour spaces.

7.7. The differences between claim no. 1 of the present invention and the claims of D3 are as under:

<i>Present Invention</i>	<i>D3</i>
<i>A video coding device comprising generation means for generating the prediction error signal from an input image; selecting means for selecting</i>	<i>Claim no. 1 of D3 corresponding the Subject Application, switching from a first color space to a second color</i>



<p><i>from among a plurality of colour spaces, a colour space of the prediction error signal in block units, transformation means for transforming the prediction error signal depending on the selected colour space.</i></p>	<p><i>space.</i></p>
<p><i>Adaptive chroma quantization offset derivation means for deriving a chroma quantization offset, which is a parameter for adjusting a QP of each chroma component, for each of the plurality of colour spaces.</i></p>	<p><i>Claim no. 1 of D3, adjusting final QP values or intermediate QP values for colour components of the second colour space according to per component colour space adjustment factors, wherein the first colour space is RGB and the second colour space is YCoCg, and wherein the per 10 component colour space adjustment factors adjust the final QP values or intermediate QP values for the colour components of the second colour space by offsets of -5, -3 and -5 for Y, Co, and Cg components.</i></p>
<p><i>Quantization means for generating a quantization coefficient image based on said prediction error signal or the transformed prediction error signal by the transformation means; and inverse quantization means for inverse-quantizing the quantization coefficient image by using each of the chroma quantization offsets for the selected colour space.</i></p>	<p><i>Claim no. 2 of D3 corresponding the Subject Application, decoder switching to a first colour space from a second colour space between two of the units, adjusting final QP values or intermediate QP values for colour components of the second colour space according to per component colour space adjustment factors, wherein the first colour space is RGB and the second colour space is YCoCg, and wherein the per component colour space adjustment factors adjust the final QP values or intermediate QP values for the colour components of the second colour space by 25 offsets of -5, -3 and -5 for Y, Co and Cg components, respectively.</i></p>



- 7.8. In D3's claims, it is specifically not mentioned that RGB space is modified, but it is necessary that it can be modified. It can be seen in D3 that two different syntax elements can indicate a slice QP offset for the first colour space and a slice QP offset for the second colour space, respectively. Reliance was placed upon Paragraph No. [0149] of D3 while making the above submission.
- 7.9. Reliance was placed upon the decision in ***Boehringer Ingelheim Pharma GMBH & Co. KG v. Vee Excel Drugs and Pharmaceuticals Private Ltd. and Others***, 2023 SCC OnLine Del 1889, wherein the Court culled out the factors that are to be considered in order for a patent to be revoked under Section 64(1)(a) of the Act. Further, the Court in ***FMC Corporation & Ors. v. Nacto Pharma Limited***, Neutral Citation: 2025:DHC:10092 reiterated the factors laid out in ***Boehringer Ingelheim Pharma GMBH & Co. KG (supra)***. The relevant paragraphs of ***Boehringer Ingelheim Pharma GMBH & Co. KG (supra)*** are reproduced hereunder:

“54. In order for a patent to be revoked under Section 64(1)(a) of the Patents Act, the following factors have to be established:

- i. The prior patent has to be the one granted in India.*
- ii. The said prior patent has to have an earlier priority date than the latter patent application.*
- iii. The invention claimed in the latter patent was also claimed in the earlier patent application.*
- iv. The date of publication of prior patent is irrelevant.*

55. In the present case, it is undisputed that the genus patent, IN '719, is an Indian patent having an earlier priority date than the species patent, IN '301. Therefore, what has to be examined is whether what has been



claimed in the species patent, has been claimed in the genus patent. The fact that in the present case, the publication date of the genus patent was after the priority date of the species patent, would not be relevant.”

7.10. Accordingly, the Impugned Order ought to be upheld, and the present Appeal is liable to be dismissed.

ANALYSIS AND FINDINGS

THE INVENTION

8. The present invention titled “*VIDEO CODING DEVICE, VIDEO DECODING DEVICE, VIDEO CODING METHOD, VIDEO DECODING METHOD AND PROGRAM*” and pertains to a video coding and decoding by using a device adaptive color transform in residual domain and a chroma quantization offset. The “*Technical Field*” of the present invention is hereunder:

“Technical Field

[0001] The present invention relates to a video coding device and a video decoding device using an adaptive color transform in residual domain and a chroma (color difference) quantization offset.”

9. The problem is described under Paragraph No. [0051] of the Complete Specification of the Subject Application. The chroma quantization offset technique pertains to signalling chroma quantization offset values for second colour component and third colour component. In case the adaptive colour transforms into residual domain combines with the chroma quantization offset, the RGB space blocks and YCoCr space blocks share the same quantization strength, making it challenging to set the quantization strength appropriately for each of the colour space. Therefore, the chroma quantization offset technique cannot be used to obtain subjective image



quality improvement effect. The technical problem solved as described in the Complete Specification is hereunder:

*“[0051] The chroma quantization offset technique is a technique of signaling the chroma quantization offset values for the second color component and the third color component. **Therefore, if the adaptive color transform in residual domain is combined with the chroma 20 quantization offset, the block compressed in the RGB space and the block compressed in the YCoCr space share the quantization strength as illustrated in Fig. 20. Thereby, the quantization strength cannot be set appropriately according to the color space. Thus, the subjective image quality improvement effect cannot be acquired by the chroma quantization offset technique.**”*

10. Paragraph No. [0053] of the Complete Specification of the Subject Application states that video coding device can select from among a plurality of colour spaces, a colour space of a prediction error signal in code block units. The video coding device also includes adaptive chroma quantization offset derivation means for deriving a chroma quantization offset for each colour space. As per the Complete Specification of the present invention, the video coding device further includes inverse quantization means for inverse-quantizing a quantization coefficient image through using the chroma quantization offset for each colour space. Additionally, the Complete Specification also discloses that the video decoding device further includes inverse quantization means for inverse-quantizing a quantization coefficient image by using the chroma quantization offset derived for each colour space. The relevant paragraphs of the Complete Specification of the Subject Application are reproduced hereunder:

*“[0053] According to the present invention, there is provided a video coding device **capable of selecting, from among a plurality of color spaces, a color space of a prediction error signal in coded block units,** the device including: **adaptive chroma quantization offset***



derivation means for deriving a chroma quantization offset for each color space; and inverse quantization " means for inverse-quantizing a quantization coefficient image by using the chroma quantization offset for each color space.

[0054] Furthermore, according to the present invention, there is provided a video decoding device capable of selecting, from among a plurality of color spaces, a color space of a prediction error signal in coded block units, the device including: adaptive chroma quantization offset derivation means for deriving a chroma quantization offset for each color space; and inverse quantization means for inverse-quantizing a quantization coefficient image by using the chroma quantization offset for each color space.

[0055] Furthermore, according to the present invention, there is provided a video 10 coding method capable of selecting, from among a plurality of color spaces, a color space of a prediction error signal in coded block units, the method including: deriving a chroma quantization offset for each color space; and inverse-quantizing a quantization coefficient image by using the chroma quantization offset for each color space.

[0056] Furthermore, according to the present invention, there is provided a video 15 decoding method capable of selecting, from among a plurality of color spaces, a color space of a prediction error signal in coded block units, the method including: deriving a chroma quantization offset for each color space; and inverse-quantizing a quantization coefficient image by using the chroma quantization offset for each color space.

*[0057] Furthermore, according to the present invention, there is provided a video 20 coding program for performing a video coding method capable of selecting, from among a plurality of color spaces, a color space of a prediction error signal in coded block units, **the program causing a computer to perform:** a process of deriving a chroma quantization offset for each color space; and a process of inverse-quantizing a quantization coefficient image by using the chroma quantization offset for each color space.*

[0058] Furthermore, according to the present invention, there is provided a video decoding program for performing a video decoding method capable of selecting, from among a plurality of color spaces, a color space of a prediction error signal in coded block units, the program causing a computer to perform: a process of deriving a chroma quantization offset for each color space; and a process of inverse-quantizing a quantization coefficient image by using 30 the chroma quantization offset for each color space.



Advantageous Effects of Invention

[0059] According to the present invention, it is possible to prevent a deterioration in a subjective image quality improvement effect.”

11. The Appellant has filed 8 amended claims at the stage of post-hearing Written Submissions. The independent claims of the Subject Application are reproduced hereunder:

“Claims

1. A video coding device comprising:

generation means (115) for generating the prediction error signal from an input image;

selecting means (101, 103, 111) for selecting, from among a plurality of color spaces, a color space of the prediction error signal in block units,

transformation means (102) for transforming the prediction error signal depending on the selected color space;

adaptive chroma quantization offset derivation means (121, 311) for deriving a chroma quantization offset, which is a parameter for adjusting a quantization parameter of each chroma component, for each of the plurality of color spaces;

quantization means (104) for generating a quantization coefficient image based on said prediction error signal or the transformed prediction error signal by the transformation means (102); and

inverse quantization means (105, 312) for inverse-quantizing the quantization coefficient image by using each of the chroma quantization offsets for the selected color space.

4. A video decoding device comprising:

entropy decoding means (212) for parsing a bitstream to get information indicating a color space selected from among a plurality of color spaces;

adaptive chroma quantization offset derivation means (221, 411) for deriving a chroma quantization offset, which is a parameter for adjusting a quantization parameter of each chroma component, for each of the plurality of color space; and

inverse quantization means (205, 412) for inverse-quantizing a quantization coefficient image by using each of the chroma quantization offsets for the selected color space.



7. A video coding method comprising:
generating a prediction error signal from an input image; selecting, from among a plurality of color spaces, a color space of the prediction error signal in block units;
transforming the prediction error signal depending on the selected color space; deriving a chroma quantization offset, which is a parameter for adjusting a quantization parameter of each chroma component, for each of the plurality of color spaces;
generating a quantization coefficient image based on said prediction error signal or the transformed prediction error signal; and
inverse-quantizing the quantization coefficient image by using each of the chroma quantization offsets for the selected color space.

8. A video decoding method comprising:
parsing a bitstream to get information indicating a color space selected from among a plurality of color spaces;
deriving a chroma quantization offset, which is a parameter for adjusting a quantization parameter of each chroma component, for each of the plurality of color spaces; and
inverse-quantizing the quantization coefficient image by using each of the chroma quantization offsets for the selected color space.”

12. It is reemphasized that claim no. 1 of the Subject Application defines ‘chroma quantization offset’ as a parameter for adjusting a QP of each chroma component and does not take the luma component into consideration. The Impugned Order citing the prior arts D1 to D3 held that the Appellant’s contended that D1 merely discloses derivation of chroma quantization offset for colour components and not for a plurality of colour spaces and distinguished the invention from D1 to D3 on the ground of selection among multiple colour spaces. However, such submissions were found unpersuasive as D1, read with D2, discloses adaptive colour transform and switching between colour spaces at the coding unit level. It was held that D1 teaches adjustment of QPs, including offsets (-5, -3, or 0), contingent upon the adaptive colour transform flag, thereby satisfying the



2026:DHC:2598



claimed feature of chroma quantization offset for each colour space. Further, D2 and D3 were found to disclose similar techniques, including derivation and application of quantization offsets depending on colour space transformation. In particular, as per the Impugned Order, D3 explicitly teaches derivation and transmission of separate quantization offsets for multiple colour spaces. The claims were construed broadly and held not to exclude offsets for Y or 0 value offsets, thereby encompassing the prior art disclosures. Consequently, the present invention was held to lack inventive step in view of D1 to D3.

13. The Appellant has raised the issue of admissibility of D3 as prior art. The relevant portion of the cited D3 showing the date of publication being 01.10.2015 is reproduced hereunder:

(12) INTERNATIONAL APPLICATION PUBLISHED UNDER THE PATENT COOPERATION TREATY (PCT)
 (19) World Intellectual Property Organization
 International Bureau



(43) International Publication Date
 1 October 2015 (01.10.2015)

(10) International Publication Number
WO 2015/143671 A1

The bibliographic details of D3 are reproduced hereunder:

Application No.	201647032651
Filing Date	September 23, 2016
PCT International Application No.	PCT/CN2014/074197
Filing Date (International Application)	March 27, 2014
Publication Date (International Application)	October 01, 2015
Publication Date (Indian Application)	November 11, 2016

14. D3 was relied upon by the learned Controller in the Hearing Notice as well in the Impugned Order. It is important to note that D3 was published on 01.10.2015, which is subsequent to the priority date of the Subject



Application. The priority date of the Subject Application was 03.10.2014. However, the prior art document can be cited for the anticipation by prior claiming. This is also submitted by the learned Counsel for the Appellant that D3 could possibly be cited only under Section 13(1)(b) of the Act. The learned Counsel for the Appellant further submitted that in the present case, the Respondent has to establish that the scope of claims of the Subject Application is identical to that of D3. The Appellant submitted that in this case only the valid claims, that is the claims granted in D3 can be invoked and since the D3 is still pending and claims of D3 are yet to be granted, it cannot be invoked under section 13(1)(b) of the Act. However, this Court is of the view that since the claims must be read in conjunction with the specifications, to the extent of such conjunction, D3 can be cited.

15. D1 which is titled as “*HEVC Screen Content Coding*” pertains to screen content coding text, based on the seventh draft of HEVC range extension, i.e., JCTVC-Q1005_v9. The learned Counsel for the Appellant cited Section 8.6.2 of D1 and submitted that it only teaches deriving an adaptive chroma quantization offset for each of the plurality of colour components. The Section 8.6.2 of D1 is reproduced hereunder:

“8.6.2 *Scaling and transformation process*

Inputs to this process are:

- a luma location (x_{TbY} , y_{TbY}) specifying the top-left sample of the current luma transform block relative to the top-left luma sample of the current picture,*
- a variable $trafoDepth$ specifying the hierarchy depth of the current block relative to the coding block,*
- a variable $cIdx$ specifying the colour component of the current block,*
- a variable $nTbS$ specifying the size of the current transform block.*



Output of this process is the $(nTbS) \times (nTbS)$ array of residual samples r with elements $r[x][y]$.

The quantization parameter qP is derived as follows:

– If $cIdx$ is equal to 0,

$$qP = Qp'_Y + (cu_residual_act_flag[xTbY][yTbY] - 5 : 0) \quad (8-261)$$

– Otherwise, if $cIdx$ is equal to 1,

$$qP = Qp'_{Cb} + (cu_residual_act_flag[xTbY][yTbY] - 5 : 0) \quad (8-262)$$

– Otherwise ($cIdx$ is equal to 2),

$$qP = Qp'_{Cr} + (cu_residual_act_flag[xTbY][yTbY] - 3 : 0) \quad (8-263)$$

.....”

16. Section 8.6.2 of D1, under equations (8-261) to (8-263) discusses the adaptive chroma quantization offset derivation pertains to deriving a chroma quantization offset that is a parameter for adjusting a QP of each chroma component for every plurality of colour spaces. Therefore, it can be stated that the cited document D1 discloses the feature “*chroma quantization offset for each of the plurality of color spaces*”. Further, Section 8.4 of D1 discusses the decoding process for coding units coded in intra prediction mode. Additionally, Section 8.6.8 of D1 discusses the residual modification process for transform blocks using adaptive colour transform. Section 8.6.8 of D1 is invoked when the adaptive colour transform flag is enabled, discloses modification of colour components as per the specified equations and thereby performing a transformation of the colour space.

17. Section 8.4 of D1 discusses that when the `cu_residual_act_flag` is set to 1, the residual modification process for residual blocks is invoked by using adaptive colour transform in accordance with the specification given under sub-clause 8.6.8 of Section 8.4. Section 8.6.8 of D1 is reproduced hereunder:



“8.6.8 Residual modification process for transform blocks using adaptive colour transform

This process is only invoked when *ChromaArrayType* is equal to 3.

Inputs to this process are:

- a variable *blkSize* specifying the block size,
- an $(blkSize) \times (blkSize)$ array of luma residual samples r_Y with elements $r_Y[x][y]$,
- an $(blkSize) \times (blkSize)$ array of chroma residual samples r_{Cb} with elements $r_{Cb}[x][y]$,
- an $(blkSize) \times (blkSize)$ array of chroma residual samples r_{Cr} with elements $r_{Cr}[x][y]$.

Outputs of this process are:

- an modified $(blkSize) \times (blkSize)$ array r_Y of luma residual samples,
- an modified $(blkSize) \times (blkSize)$ array r_{Cb} of chroma residual samples,
- an modified $(blkSize) \times (blkSize)$ array r_{Cr} of chroma residual samples.

The $(blkSize) \times (blkSize)$ arrays of residual samples r_Y , r_{Cb} and r_{Cr} are modified as follows:

- If *cu_transquant_bypass_flag* is equal to 1, the $(blkSize) \times (blkSize)$ arrays of residual samples r_Y , r_{Cb} and r_{Cr} with $x = 0..blkSize - 1$, $y = 0..blkSize - 1$ are modified as follows:

$$\begin{aligned} tmp &= r_Y[x][y] - (r_{Cb}[x][y] \gg 1) \\ r_Y[x][y] &= tmp + r_{Cb}[x][y] \\ r_{Cb}[x][y] &= tmp - (r_{Cr}[x][y] \gg 1) \\ r_{Cr}[x][y] &= r_{Cb}[x][y] + r_{Cr}[x][y] \end{aligned}$$

- Otherwise (*cu_transquant_bypass_flag* is equal to 0), the $(blkSize) \times (blkSize)$ arrays of residual samples r_Y , r_{Cb} and r_{Cr} with $x = 0..blkSize - 1$, $y = 0..blkSize - 1$ are modified as follows:

$$\begin{aligned} tmp &= r_Y[x][y] - r_{Cb}[x][y] \\ r_Y[x][y] &= r_Y[x][y] + r_{Cb}[x][y] \\ r_{Cb}[x][y] &= tmp - r_{Cr}[x][y] \\ r_{Cr}[x][y] &= tmp + r_{Cr}[x][y] \\ &\dots \end{aligned}$$



2026:DHC:2598



18. Section 7.4.9.5 of D1 defines the flag such that a value of 1 specifies that adaptive colour transform is applied to the residual samples of the current coding unit. Therefore, based on the above disclosure made in D1, it can be stated that D1 discloses selecting from among a plurality of colour spaces, specifically second colour spaces and performing switching of the colour space in coding units and thereby anticipating this feature of the claim. Since D1 under Section 8.6.2 discloses adjustment of QPs for both chroma and luma components based on the adaptive colour transform flag in which a value of -5, -3, or 0 is added to the QPs of the three colour components. It can be stated that this adjustment value constitutes a quantization offset within the meaning of the claim, as it serves as a parameter for adjusting the QP of each colour component. The adjustment value depends on the `cu_residual_act_flag` and thereby rendering the quantization offset derivation adaptive in nature. Therefore, it can be stated that D1 discloses deriving a QP offset for each of the plurality of colour spaces in which an offset value of 0 is applied when no adaptive colour transform is used, and an offset value of -5 or -3 is applied when adaptive colour transform is applied and hence, anticipating the adaptive chroma quantization offset derivation feature of the claim. The Impugned Order rightly provides the abovementioned reason with respect to the D1.

19. It is important to note that Figure No. 1 of the Complete Specification of the Subject Application illustrates an embodiment of a video coding device according to the present invention. Further, Figure No. 18 of the Complete Specification of the Subject Application, illustrates the function of adaptive colour transform in residual domain is combined with the chroma



quantization offset. Figure No. 18 of the Complete Specification of the Subject Application is reproduced hereunder:

FIG. 18

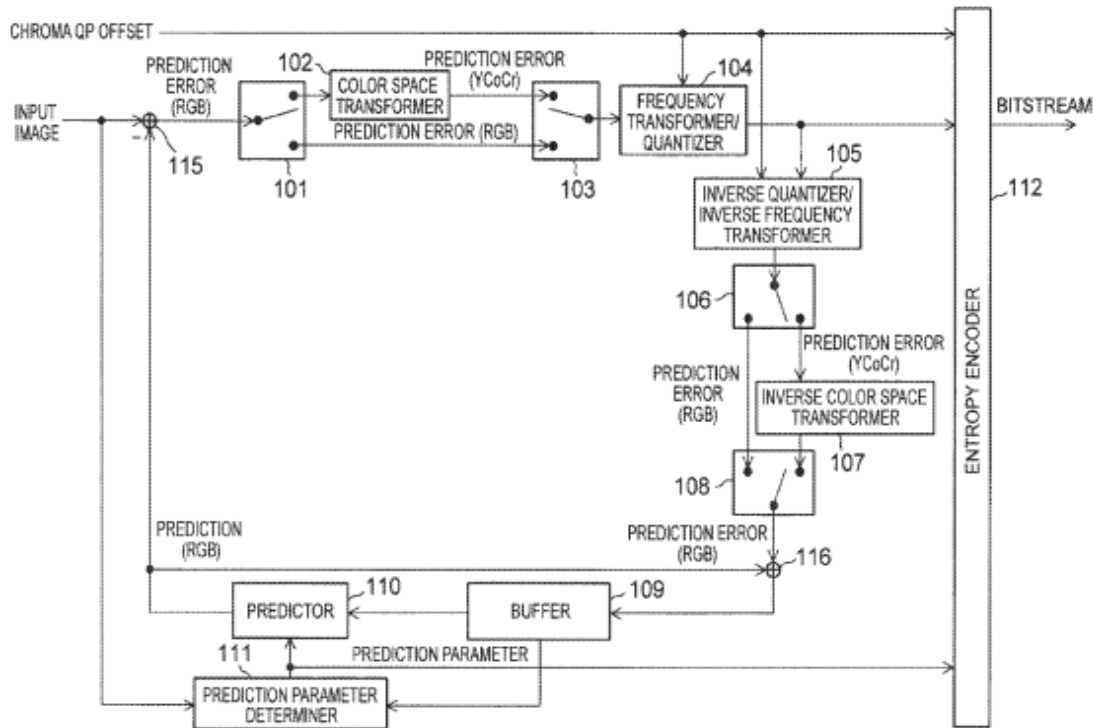

20. The learned Counsel for the Appellant states that the switch 101, the colour space transformer 102, the switch 103 as well as the frequency transformer / quantizer 104, the inverse quantizer / inverse frequency transformer 105, the inverse colour space transformer 107, the switch 108, the buffer 109, the predictor 110, the subtractor 115, the switch 106 as well as the adder 116 operate in the same manner as those illustrated in Figure No. 18.

21. D2 discloses by using the delta QPs by (-5, -3, -5) to adjusting the normal QP when the colour space transform is applied. It would be obvious for a PSITA to derive that if the colour space transform is not applied, the 'normal' QP should remain unmodified and therefore, implying a delta QP



offset of 0. The PSITA, from this disclosure, can understand that if the colour space transform is not applied, the ‘normal’ QP should not be modified and therefore, the delta QP, or the QP offset should be 0.

22. Claim No. 1 of D3 discloses adjusting final or intermediate QP values for colour components of a second colour space (YCoCg) by using per-component adjustment factors in which the QP offsets applied to the Y, Co, and Cg components are -5, -3, and -5, respectively, relative to the first colour space (RGB). Further, Claim No. 2 of D3 discloses a decoder that switches from a second colour space (YCoCg) to a first colour space (RGB) between processing units and adjusts final or intermediate QP values for the YCoCg components by using per-component factors with offsets of -5, -3, and -5 for Y, Co, and Cg, respectively.

23. It can be stated from the claims that it specifically does not mention that RGB space is modified. However, such modifications are implicit and supported by the disclosure. Paragraph No. [0149] of D3 describes two different syntax elements i.e., slice QP offset for the first colour space and a slice QP offset for the second colour space, respectively. Therefore, this indicates that QP adjustment is applicable to both colour spaces and the absence of a specific mentioning of RGB space modification in the claims does not preclude its applicability. Paragraph No. [0149] is reproduced hereunder:

“[0149] Instead of using a single syntax element for a slice QP offset, two different syntax elements can indicate a slice QP offset for the first color space and a slice QP offset for the second color space, respectively. For example, slice_qp_delta can indicate the QP offset for a slice when the first color space is used within the slice, and slice_qp_delta_cs2 can indicate the QP offset for the slice when the second color space is used within the slice. The syntax element slice_qp_delta_cs2 can be conditionally signaled when at least two



2026:DHC:2598



color spaces are used. The syntax element slice_qp_delta_cs2 can indicate a difference relative to the QP value for the slice for the first color space. That is, the QP value for the slice for the first color space is $26 + \text{init_qp_minus_26} + \text{slice_qp_delta}$, and the QP value for the slice for the second color space is $26 + \text{init_qp_minus_26} + \text{slice_qp_delta} + \text{slice_qp_delta_cs2}$. Alternatively, the syntax element slice_qp_delta_cs2 can indicate a difference relative to the initial QP value for the picture. That is, the QP value for the slice when the second color space is used is $26 + \text{init_qp_minus_26} + \text{slice_qp_delta_cs2}$.”

24. Therefore, the contentions advanced by the Appellant that D1 to D3 are confined merely to colour space conversion or switching, akin to transformation in the present invention, and do not disclose the concept of selecting a colour space from among a plurality of colour spaces, is found to be untenable and is, accordingly, rejected.

25. In view of the above, the subject matter of the present invention stands rendered obvious in light of the disclosures contained in D1 to D3, and, thus, fails to satisfy the requirement of inventive step under Section 2(1)(ja) of the Act.

26. Accordingly, the present Appeal, being devoid of merit, is dismissed.

TEJAS KARIA, J

MARCH 28, 2026

‘KC’ / ‘N’